

# 3-Point Rod Latch RS

1-400



## Advantages

- For quarter-turn cutout Pr20.1.
- For round rods  $\varnothing$  8mm.
- Heavy duty version.
- RH / LH version.
- In combination with lock support for bending 20 or 26mm.

## Material

- **Rod latch:** steel, zinc plated and zinc die
- **Lock support:** steel, zinc plated

## Remarks

1. stroke
2. for painted doors and bolted lock, an M6x8 weld-stud with nut is required for the earthing.
3. length
4. clearance

Escutcheon with insert PS 1-430.01.

T- and L-handles PS 1-430.

Swinghandles PS 2-300.



## Rod latch for round rods

	Product number	Version	Stroke	Threaded size rod latch	Installation type	Delivery Unit
a)	235-9001.00-00000	RH version	13 mm	-	screw- / weld-on	1 pc.
a)	235-9002.00-00000	LH version	13 mm	-	screw- / weld-on	1 pc.
a)	235-9003.00-00000	RH version	18 mm	-	screw- / weld-on	1 pc.
a)	235-9004.00-00000	LH version	18 mm	-	screw- / weld-on	1 pc.
a)	235-9005.00-00000	RH version	13 mm	M8	screw- / weld-on	1 pc.

---

	Product number	Version	Stroke	Threaded size rod latch	Installation type	Delivery Unit
a)	235-9006.00-00000	LH version	13 mm	M8	screw- / weld-on	1 pc.
a)	235-9007.00-00000	RH version	18 mm	M8	screw- / weld-on	1 pc.
a)	235-9008.00-00000	LH version	18 mm	M8	screw- / weld-on	1 pc.

---

## Lock support for rod latch

	Product number	Name	Delivery Unit
b)	235-1001.00-00000	Lock support A20	1 pc.
b1)	235-1002.00-00000	Lock support A26	1 pc.

---

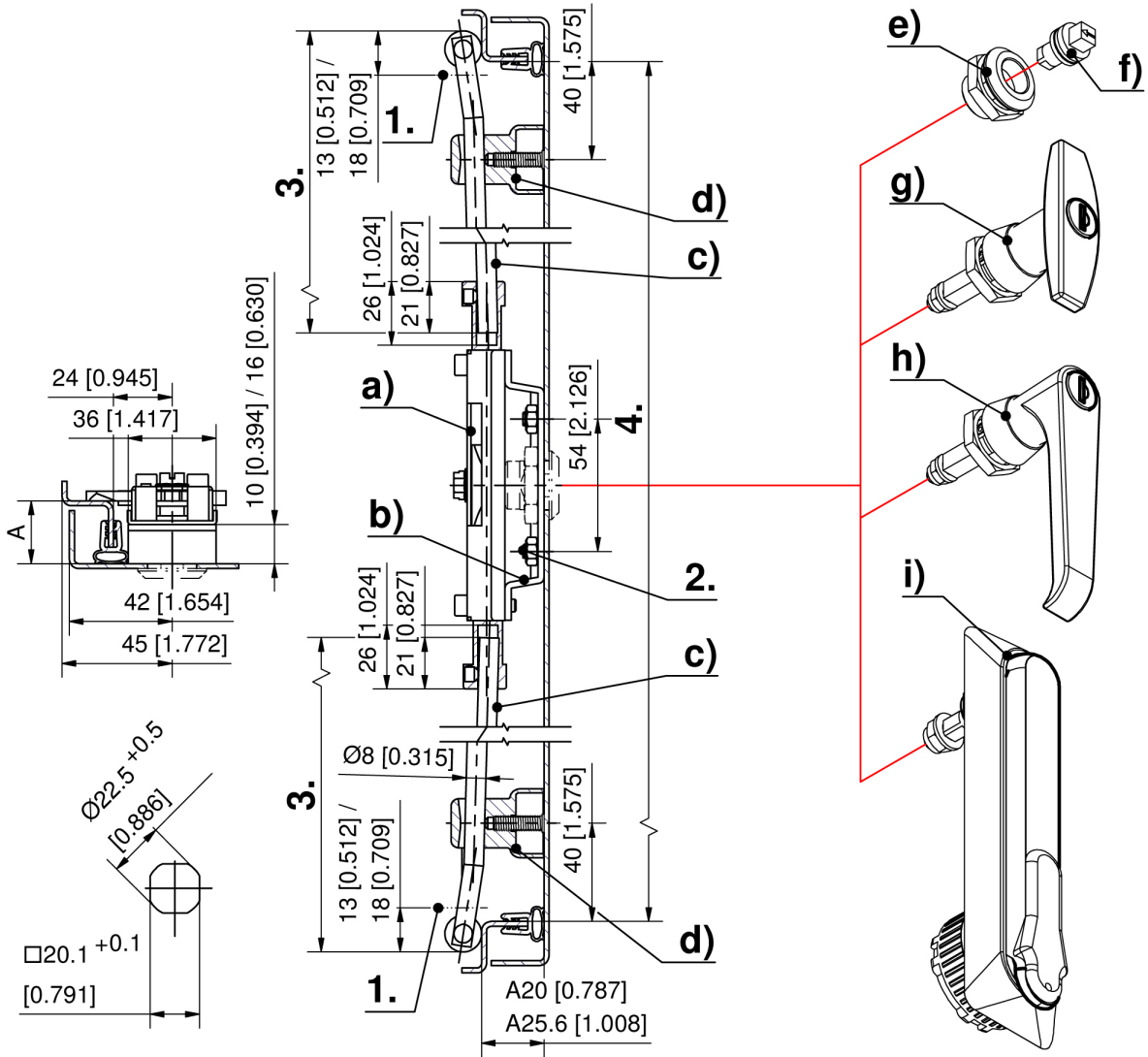

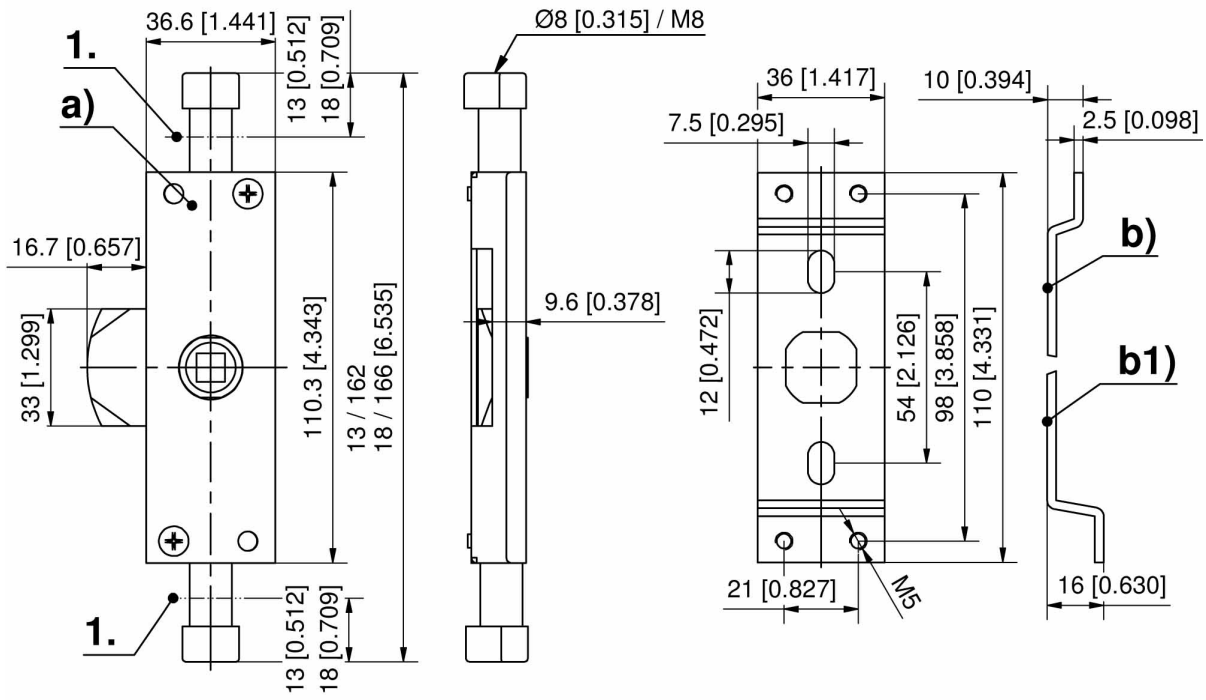



**3-Point Rod Latch RS**  
for Escutcheon 1-430 / 1-430.01,  
max. 3-point locking, inside the sealed area

[1-400.900]

