

Rod Guide RS

1-193



Advantages

- For 8mm round rods for installation without tools on weld-stud M6x20mm.
- The rod guide has to be placed over the weld stud and then pushed onto the thread until a "click" is audible. It is locked now in the final position.
- Visual inspection possible from above through openings.
- The rod guide can be removed from the threaded stud by inserting a flat head screwdriver, pushing the jaws apart and sliding the rod guide out.



Material

- **Rod guide:** PA6, black

Remarks

Completely pre-assembled rod latches (including 3-point cam, round rod, rollers and rod guide) can also be mounted with this rod guide, as the rod guide is simply pushed over the weld stud.

The rod guide must be installed as shown in the figure.

Rod guide

Product number	Height H	A = bending	L	Installation type	Delivery Unit
200-3616.54-00000	35 mm	A24	28 mm	tool-less	1 pc.
200-3617.54-00000	37 mm	A26	30 mm	tool-less	1 pc.
200-3618.54-00000	39 mm	A28	32 mm	tool-less	1 pc.

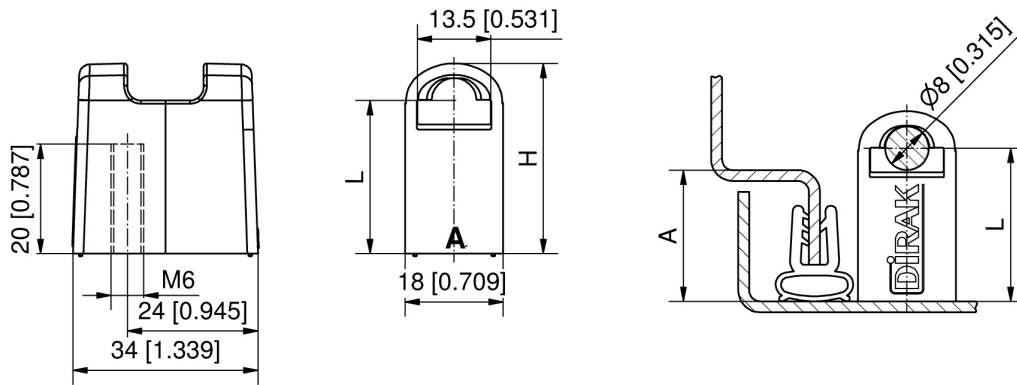

Operation

