

Compression Rod Latch RS / FS

3-211



Advantages

- For installation inside door sealing.
- Compression 4mm.
- Single or multi-point latching by using of additional latching devices.
- The connecting rods between the latching devices can be fixed easily in guides.
- For round rods $\varnothing 8\text{mm}$ or flat rods 3 x 14 mm.
- Oblong hole allows for installation adjustment.
- Seismic-proof according to GR-63-CORE, Issue 4.
- Vibration-proof according to DIN EN 61373.
- RH and LH version.
- Grounding by grounding clip (optional).

Material

- **Housing, driving rods, pinion:** zinc die

Remarks

Clamps and rod latch adapter can be ordered optionally (PS 3-220).

If the rod latch adapter is used, clamps must also be ordered.

If the rod latch adapter is not used, a bent round rod from PS 3-221 must be fitted and clamps are not required. Round rods are screwed together. Screws and nuts are not included in the scope of delivery.

Variant with clamps (108-9000.00-00000): For round rods $\varnothing 8\text{mm}$ or flat rods 3 x 14mm. The connecting rods (PS 3-221) between the compression elements are simply fastened in the clamps.

Closing process:

1. a 90° turn of the swinghandle brings the cam into the locked position.
2. with another 45° turn the cam is pressed by 4mm against the clamping surface.

For reasons of strength and stability, DIRAK recommends the use of round rods.

Drive elements are always mounted on the latch. The closing process should always be carried out under tensile load. When closed, the racks are retracted!

Other variants available on request.

Please contact one of our technical advisors before placing an order.

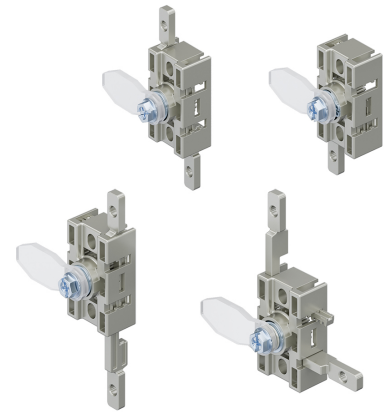

Compression rod latch, 1 driving rod

	Product number	Installation type	Stroke	Delivery Unit	Version
b)	208-9078.00-30000	screw-on	23 mm	1 pc.	LH
b1)	208-9079.00-30000	screw-on	23 mm	1 pc.	RH

Compression rod latch, 2 drivers synchronized

	Product number	Version	Stroke	Installation type	Delivery Unit
d)	208-9084.00-30000	LH	23 mm	screw-on	1 pc.
d1)	208-9085.00-30000	RH	23 mm	screw-on	1 pc.

Compression rod latch, 2 driving rods, bidirectional running direction

	Product number	Version	Stroke	Installation type	Delivery Unit
e)	208-9082.00-30000	for left-hand doors, bottom	23 mm	screw-on	1 pc.
e1)	208-9083.00-30000	for right-hand doors, bottom	23 mm	screw-on	1 pc.
f)	208-9090.00-30000	for left-hand doors, top	23 mm	screw-on	1 pc.
f1)	208-9091.00-30000	for right-hand doors, top	23 mm	screw-on	1 pc.

Compression latch, drive elements

	Product number	Version	Number of rods	Stroke	Installation type	Delivery Unit
c)	208-9078.00-30001	LH	1 driving rod	23 mm	screw-on	1 pc.
c1)	208-9079.00-30001	RH	1 driving rod	23 mm	screw-on	1 pc.
a)	208-9076.00-30000	LH	2 driving rods, running in opposite directions	23 mm	screw-on	1 pc.
a1)	208-9077.00-30000	RH	2 driving rods, running in opposite directions	23 mm	screw-on	1 pc.

