

# Swinghandle RS PrC Stainless Steel

7-065



## Advantages

- For cutout C and round rods.
- Swinghandle with liftable operating lever.
- 90° Closing rotation.
- Can be locked with 40mm long profile-cylinders (DIN 18252) with 45° or 90° closing rotation.
- IP65 according to DIN EN 60529.
- RH / LH application.
- Grounding by grounding clip (optional).
- The opening in the dish can be filled with a rectangular blanking plate.

## Material

- **Swinghandle, dish, padlock bolt and dust cover:** AISI 316
- **Swinghandle shaft:** AISI 303
- **Blanking plate, pinion drive and cam:** AISI 304
- **Cap:** PA, black

## Remarks

(S) Door-thickness 1.5 - 2.5mm

1. stroke 18mm
2. length L
3. clearance

Profile half cylinders and their assembly must be ordered separately.



## Swinghandle for profile-cylinder

	Product number	Version	Padlock	Installation type	Delivery Unit
a)	207-9294.00-00000	without cylinder dustcover	-	screw-on	1 pc.
a)	207-9295.00-00000	with cylinder dustcover	-	screw-on	1 pc.

	Product number	Version	Padlock	Installation type	Delivery Unit
a1)	107-9284.00-00000	without cylinder dustcover	Yes	screw-on	1 pc.
a1)	107-9285.00-00000	with cylinder dustcover	Yes	screw-on	1 pc.

## Accessories Swinghandles

	Product number	Name	Delivery Unit
b)	207-2506.80-00000	Blanking plate for opening	1 pc.

## Rod control

	Product number	Delivery Unit
e)	207-9598.00-00000	1 pc.

## 3- or 4-point cams, L45

	Product number	A-dimension	Delivery Unit
e)	207-9845.00-00022	20 mm	1 pc.
e)	207-9845.00-00028	26 mm	1 pc.

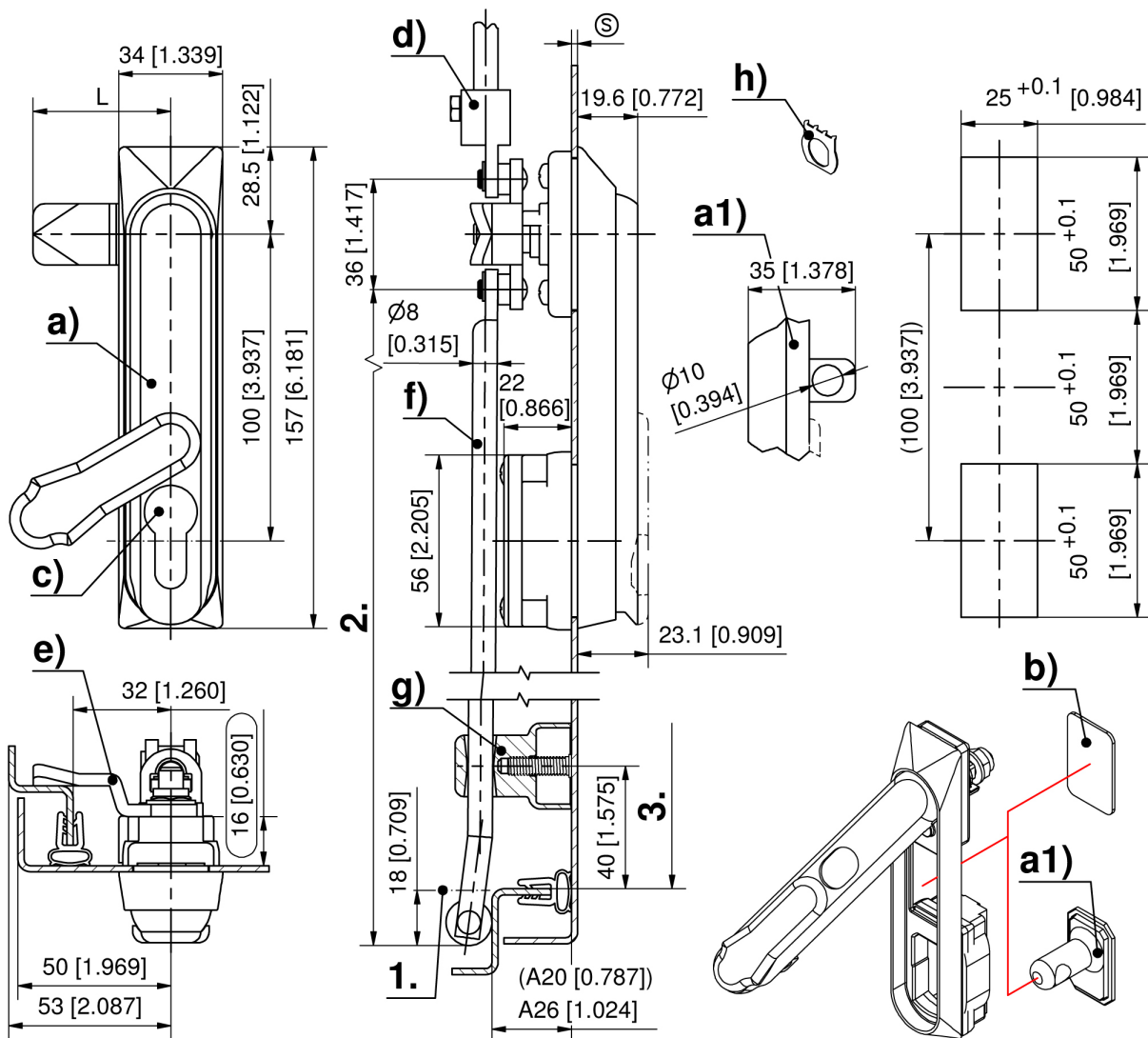

Formula for rods with eye and rollers:  
cutout in the door center (rod length varies)

$$L \text{ 2.} = \frac{\text{3. clearance} - 12\text{mm}[0.472]}{2 [0.079]} - 50 \text{ mm}[1.969] \quad L \text{ 2.} = \frac{\text{3. clearance} - 12\text{mm}[0.472]}{2 [0.079]} + 50 \text{ mm}[1.969]$$

upper rod lower rod

cutout outside the door center (rod length equal)

$$L \text{ 2.} = \frac{\text{3. clearance} - 12\text{mm}[0.472]}{2[0.079]}$$