

DST Swinghandle RS 110

2-079DST



Advantages

- Low profile design.
- The pre-assembled swinghandle (single or 3-point cam) can simply be snapped into the cutout. (2./3.)
- 90° closing rotation. (1.)
- Key cylinder DIRAK 1333 with stainless steel dust cap and 1 key with synthetic coated grip.
- RH / LH application is achieved by an adjustable cam stop. (4.)

Material

- **Swinghandle:** zinc die, black
- **Dish:** PA, black
- **Stop:** zinc die, zinc plated

Remarks

H-dimension of cam $\geq 10\text{mm}$

Drawings for rod calculation:

1. stroke 18mm
2. clearance



Swinghandle with key cylinder

Product number	Clamping range (S)	Latching type	Installation type	Delivery Unit
407-9603.00-00015	1.2 mm - 1.7 mm	keyed alike DIRAK 1333	clip-in	1 pc.
407-9603.00-00020	1.7 mm - 2.2 mm	keyed alike DIRAK 1333	clip-in	1 pc.
407-9603.00-00025	2.2 mm - 2.7 mm	keyed alike DIRAK 1333	clip-in	1 pc.

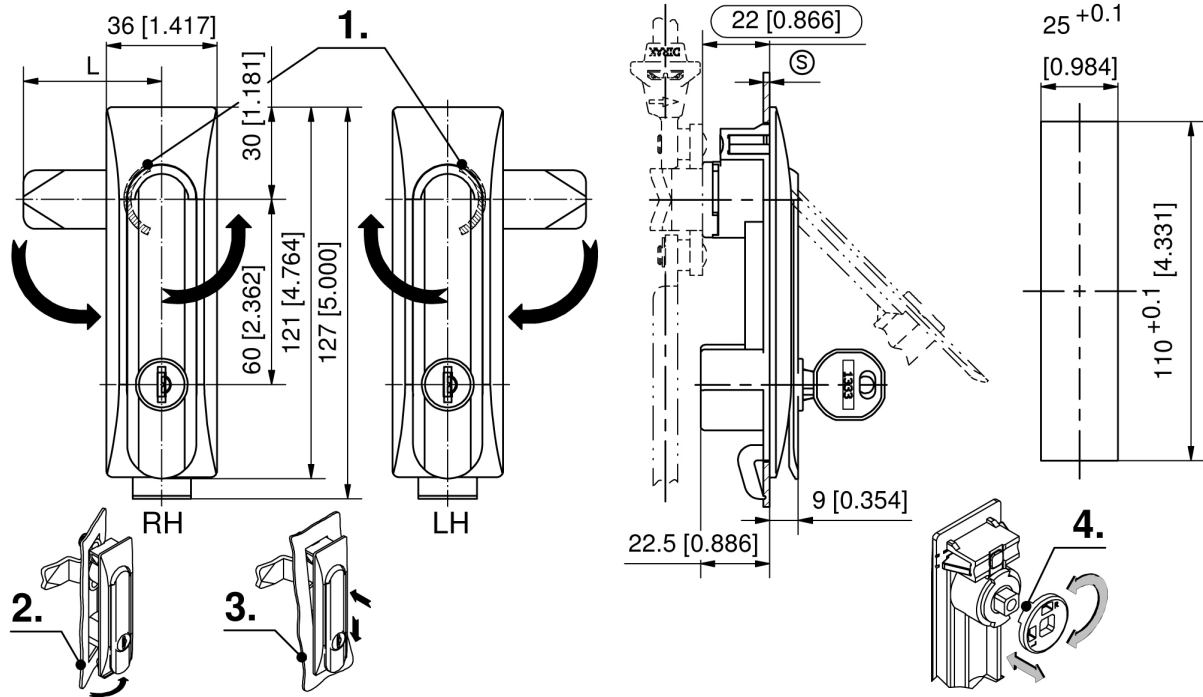

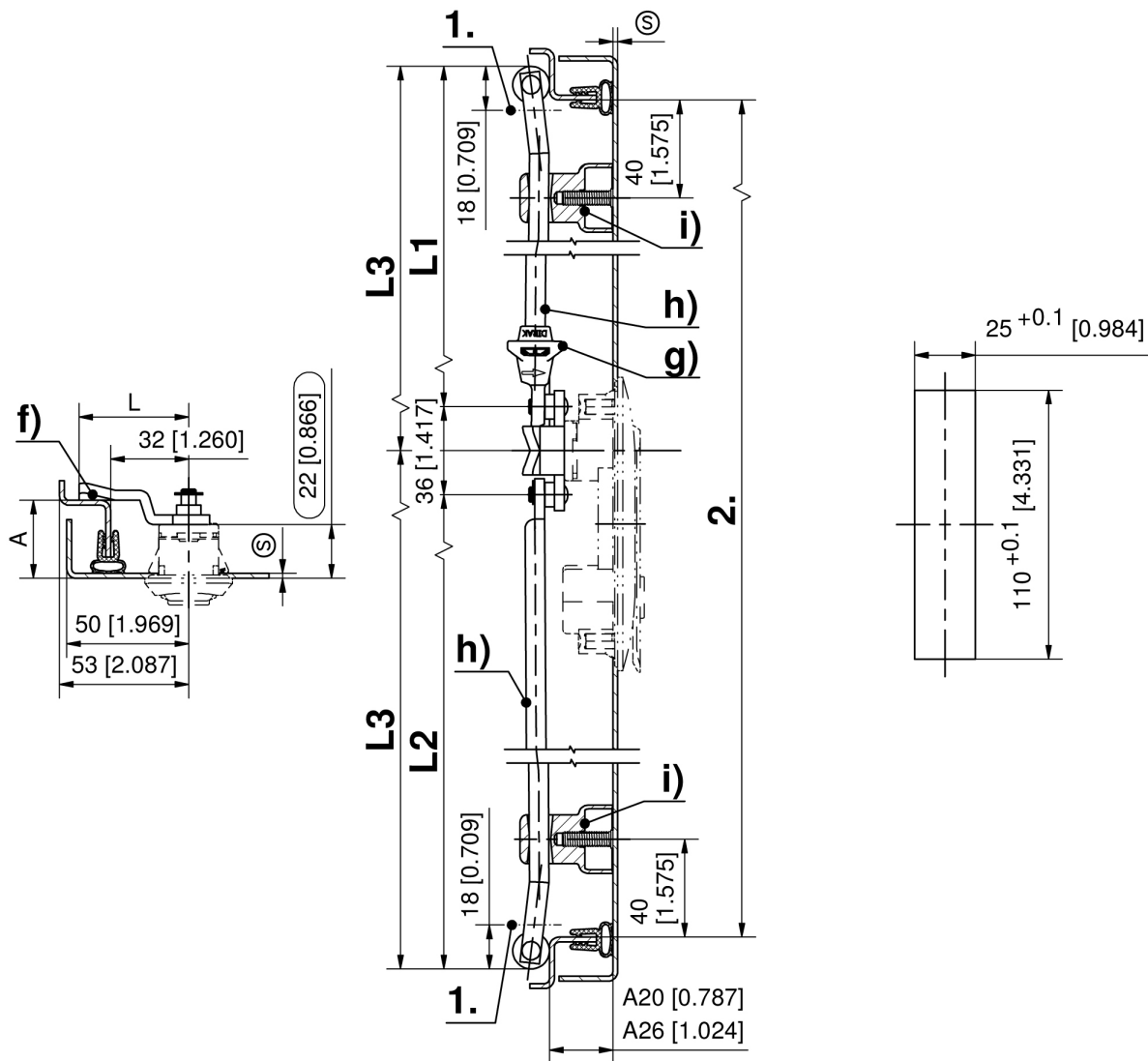

Formula for rods with eye and rollers:
cutout in the door center (rod length varies)

$$L1 = \frac{\text{upper rod}}{2} = \frac{2 \cdot \text{clearance} - 12\text{mm}[0.472]}{2 [0.079]} - 30 \text{ mm} [1.181] \quad L2 = \frac{\text{lower rod}}{2} = \frac{2 \cdot \text{clearance} - 12\text{mm}[0.472]}{2 [0.079]} + 30 \text{ mm} [1.181]$$

cutout outside the door center (rod length equal)

$$L3 = \frac{2 \cdot \text{clearance} - 12\text{mm}[0.472]}{2 [0.079]}$$