

Compression Latch Pr19.1

1-067



Advantages

- Compression 7mm.
- Housing with marking.
- Vibration-proof according to DIN EN 61373.
- IP65/67 according to DIN EN 60529.
- H-dimension variably adjustable from 39.5mm to 56mm by included straight cam.
- H-dimension variably adjustable from 12mm to 83.5mm by cams x) or y).



Material

- **Housing and insert:** zinc die, black
- **Nut for attachment of the housing:** zinc die
- **Serrated washer, nut and pin:** steel, zinc plated

Remarks

(S) Door-thickness max. 18 mm

Inserts j) and k) (see drawing) on request.

1. NOT for IP65
2. open

Compression Latch with insert, version LH, closing right

	Product number	Insert	Delivery Unit
a)	248-9752.00-00001	Square 7mm	25 pcs.
b)	248-9752.00-00002	Square 8mm	25 pcs.
c)	248-9752.00-00003	Triangular 7mm	25 pcs.
d)	248-9752.00-00004	Triangular 8mm	25 pcs.
e)	248-9752.00-00005	Double bit 3mm pin	25 pcs.

	Product number	Insert	Delivery Unit
f)	248-9752.00-00006	Double bit 5mm pin	25 pcs.
g)	248-9752.00-00007	Slotted 2x4mm	25 pcs.
h)	248-9752.00-00010	Wing knob	25 pcs.
i)	248-9752.00-00019	Conical square 9mm	25 pcs.

Cams, L33

	Product number	Bending	variable H-dimension negative	variable H-dimension positive	Delivery Unit
x)	248-0602.15-00275	27,5 mm	12 mm - 28.5 mm	67 mm - 83.5 mm	25 pcs.
y)	248-0602.15-00135	13,5 mm	26 mm - 42.5 mm	53 mm - 69.5 mm	25 pcs.

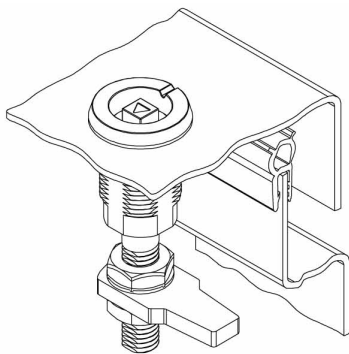
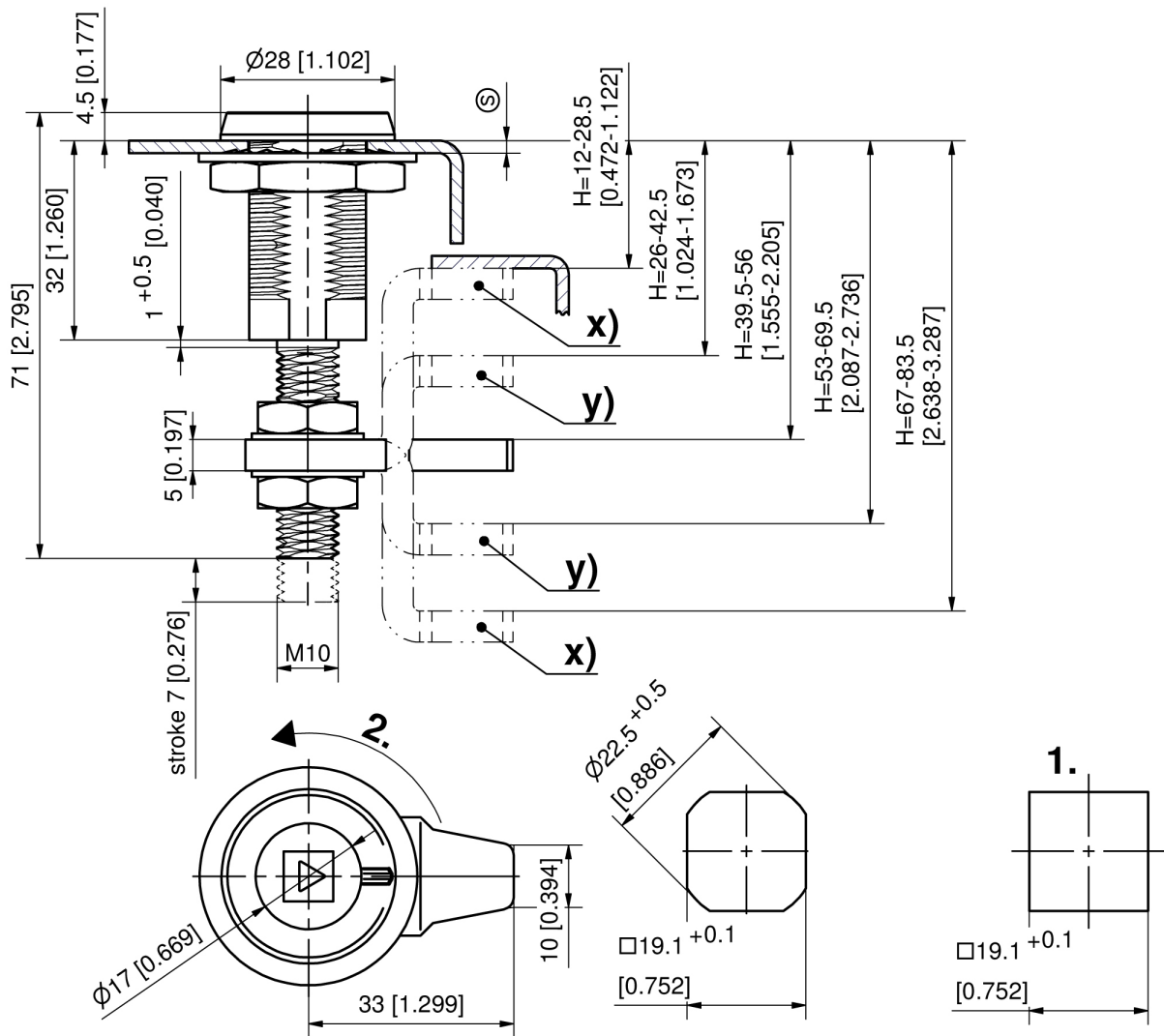

Open position

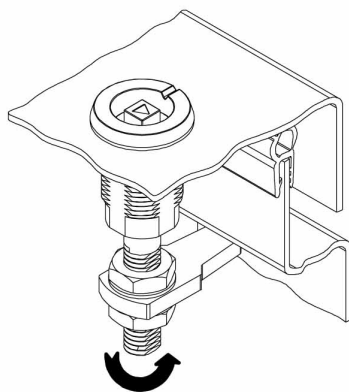

First 90° degree turn of the insert moves the cam behind the frame.

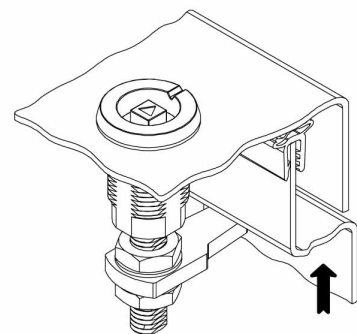

Second 90° degree turn pulls the cam 7mm against the frame compressing the seal. The door is latched and free of play.

